

Features

- Easy-to-read 6-digit electro-mechanical display for diagnostics.
- Meter has built-in wireless transceiver for in-building remote meter data collection and can interface with E-Mon wireless gateways to automatically compile data in PC-based E-Mon metering software.
- Meters with built-in wireless transceivers can be mounted inside buildings within approximately 500 feet line-of-sight from each other and up to approximately 200 feet through walls, depending on wall material.
- Revenue grade accuracy.
- On-board memory.
- Meter can be used on the following configurations:
 - 1-Phase, 2-Wire
 - 2-Phase, 3-Wire
- 0-2 volt output split-core current sensors allow for safe and accurate remote mounting of current sensors up to 2,000 feet from meter without power interruption. (Optional solid-core sensors available.)
- Non-metallic enclosure is ideal for installation inside tenant and residential spaces.
- Wireless mesh network operates in the 915 MHz license-free band. No cellular wireless service contracts are required.
- Fully self-configuring wireless mesh network allows for easy installation and configuration with no network management required.
- FCC certified not to interfere with existing infrastructure.
- Meets national accuracy standards of ANCI C12.1 and C12.16.
- UL Listed. New York City approved, Con Edison approved for RSP program. Measurement Canada approved for revenue metering. California Bureau of Weights and Measures certified.



Dim: 7" H x 6" W x 2" D

Model Numbers

120V, 1-Phase, 2W
(Supplied with 1 split-core current sensor)
2120100WT KIT (100 amp)
2120200WT KIT (200 amp)

120/208-240V, 1- or 2-Phase, 3W
(Supplied with 2 split-core current sensors)
3208100WT KIT (100 amp)
3208200WT KIT (200 amp)

Additional Components

Wireless Gateway	WGATEWAY
Wireless Meter	
Reading Software	WRSOFT

INSTALLATION OVERVIEW

CLASS 1000, 2000 and 3000 Meters

E-Mon D-Mon

Energy Monitoring Products & Systems

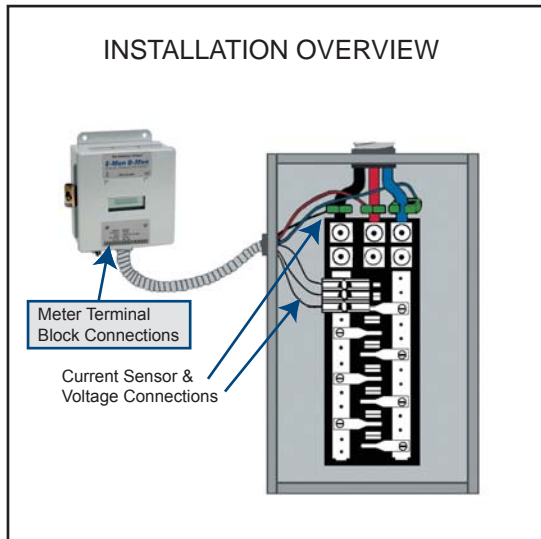

3-PHASE, 3-WIRE OR 3-PHASE, 4-WIRE INSTALLATION DIAGRAM

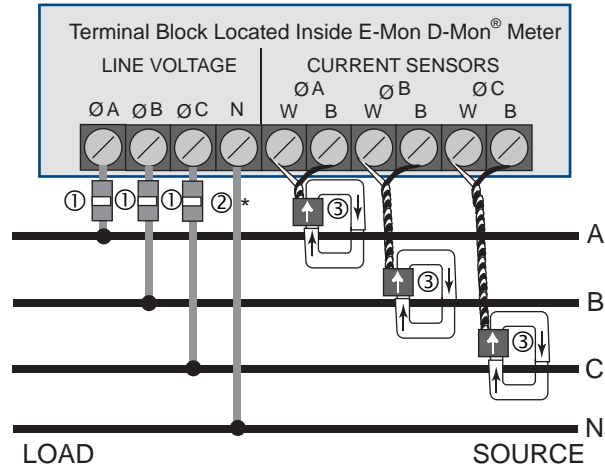

1-PHASE, 2-WIRE 120 or 277 VOLT INSTALLATION DIAGRAM (Class 1000 Series Only)

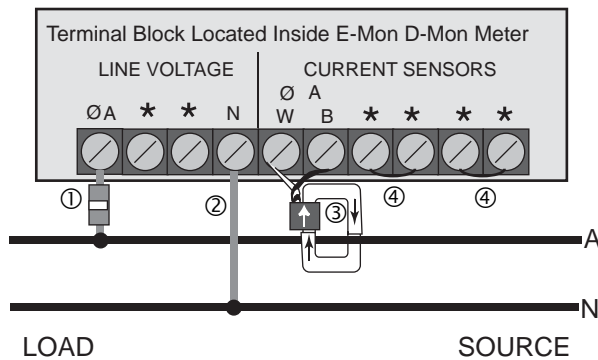

SINGLE-PHASE, 3-WIRE 120/240, 120/208 or 480 VOLT INSTALLATION DIAGRAM

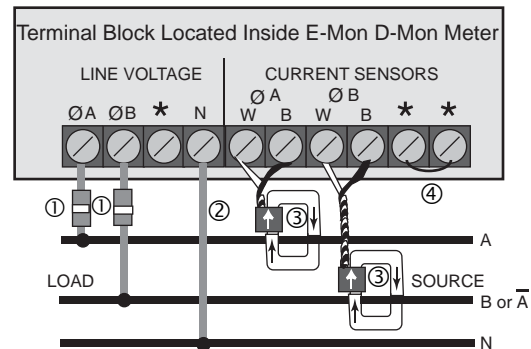

* These terminals are not used in Class 1000 installations.

- ① Recommended fuses or circuit breaker per the National Electrical Code (Meter load 6VA.)
- *② Neutral not required in delta system.
- ③ Split-core current sensors. Install according to instructions.
- ④ Install jumper.