



SR II-EB II[®] Water Meters

Displacement Type Magnetic Drive Cold Water Meters

5/8" (DN 15mm), 3/4" (DN 20mm) and 1" (DN 25mm) Sizes

Description

Applications: Measurement of cold water where flow is in one direction only; in residential, commercial and industrial services.

Conformance To Standards: Sensus SR II-EB II Water Meters meet the requirements of NSF Standard 61 and comply with ANSI/AWWA Standard C700-latest revision. Each meter is tested to insure compliance with AWWA standards.

Construction: Sensus SR II-EB II Water Meters consist of three basic components: maincase; measuring chamber; and sealed register. Maincases are made of EnviroBrass II™ C89520 alloy with externally-threaded spuds. Registers are housed in a bonnet of synthetic polymer. Measuring chambers are of Rocksyn®, a corrosion-resistant, tailored thermoplastic material formulated for long-term performance and especially suitable for aggressive water conditions. Maincase bottom plates are available in Enviro-Brass II™ or, if frost protection is desired, in cast iron or synthetic polymer®.

Sealed Register: Hermetically sealed; proven magnetic drive design eliminates dirt and moisture contamination, tampering and lens fogging problems. Standard register includes a straight-reading, odometer-type totalization display; a 360° test circle with center sweep hand; and a low flow (leak) detector. Gears are self-lubricating, molded plastic for long life and minimum friction.

No change gears are required for accuracy calibration. Encoder-type remote reading systems are available for all SR II-EB II Water Meters. (See other side of sheet for additional information.)

Tamperproof Features: A unique locking system prevents customer removal of the register to obtain free water. A special tool, available only to water utilities, is required to remove the register bonnet.

Magnetic Drive: The SR II-EB II features a hydrodynamically cushioned design that eliminates premature wear of components. The meter utilizes a patented positive, reliable drive coupling. The high-strength magnets used will eliminate "drive slip" in normal use and also provide adequate strength to drive remote register units.

Operation: Water flows through the meter's strainer and into the measuring chamber where it drives the piston. The hydrodynamically balanced piston oscillates around a central hub, guided by the division plate.

A drive magnet transmits the motion of the piston to a driven magnet located within the hermetically sealed register. The driven magnet is connected to the register gear train. It reduces the piston oscillations into volume totalization units displayed on the register dial face.

Maintenance: Sensus SR II-EB II Water Meters are engineered to provide long-term value and virtually maintenance-free operation. Simplicity of design and precise machining of components allows interchangeability of parts of like-size meters, reduced parts inventory requirements, and ease of maintenance. The register can be removed without relieving the water pressure or removing the maincase from the installation.

Connections: Tailpieces/Unions for installing the meters on a variety of pipe types and sizes are available.

Specifications



5/8" SR II-EB AMR (pictured) 3/4" and 1" available

SERVICE	Measurement of cold water with flow in one direction only.
NORMAL OPERATING FLOW RANGE ^①	5/8" (DN 15mm) size: 1 to 20 gal/min. (0.25 to 4.5 m ³ /h) 3/4" (DN 20mm) size: 2 to 30 gal/min. (0.45 to 7.0 m ³ /h) 1" (DN 25mm) size: 3 to 50 gal/min. (0.7 to 11.0 m ³ /h)
ACCURACY	100% ± 1.5% of actual thruput
LOW FLOW REGISTRATION	5/8" size: 95% at 1/4 gal/min. (0.06 m ³ /h) 3/4" size: 95% at 1/2 gal/min. (0.10 m ³ /h) 1" size: 95% at 3/4 gal/min. (0.15 m ³ /h)
MAXIMUM PRESSURE LOSS	5/8" size: 7.0 psi at 20 gal/min. (0.5 bar at 4.5 m ³ /h) 3/4" size: 9.0 psi at 30 gal/min. (0.6 bar at 7.0 m ³ /h) 1" size: 7.3 psi at 50 gal/min. (0.5 bar at 11.0 m ³ /h)
MAXIMUM OPERATING PRESSURE	150 psi (10.0 bar)
MEASUREMENT ELEMENT	Oscillating piston
REGISTER ^③	Straight reading, hermetically sealed, magnetic drive. Remote reading unit optional.
STANDARD METER REGISTRATION ^③	10 gallons, 1 cubic foot, or 0.01 m ³ or 0.1 m ³ /sweep hand revolution. 10,000,000 gallons, 1,000,000 cubic feet or 100,000 m ³ capacity. 6 odometer wheels.
METER CONNECTIONS ^②	5/8" (DN 15mm) size: 3/4" (26.44mm) threads 5/8" x 3/4" (DN 15mm x 33mm) size: 1" (33.25) threads 3/4" (DN 20mm) size: 1" (33.25 threads) 3/4" x 1" (DN 20mm x 42mm) size: 1-1/4" (41.91mm) threads 1" (DN 25mm) size: 1-1/4" (41.91mm) threads (All threads are straight pipe, external type, conforming to ANSI B1.20.1 or ISO R228, if specified.)
MATERIALS	Maincase—EnviroBrass II™ C8952 alloy Register box—Synthetic polymer Measuring chamber—Rocksyn® Bottom plate—EnviroBrass II™ Magnets—Plasticized material Casing bolts—Stainless steel Strainer—Synthetic polymer

① Maximum rates listed are for intermittent flow only. Maximum continuous flow rates as specified by AWWA are: 5/8" (DN 15mm)—10 gal/min (2.3 m³/h), 3/4" (DN 20mm)—15 gal/min (3.4 m³/h) 1" (DN 25mm)—25 gal/min (5.7 m³/h)

② Unless otherwise noted, 5/8" size and 5/8" x 3/4" characteristics are identical. (5/8" x 3/4" designates 5/8" with 3/4" connection thread.) Also unless otherwise noted 3/4" size and 3/4" x 1" size characteristics are identical. (3/4" x 1" designates 3/4" with 1" connection thread.)

Metric designation is the normal bore x the outside diameter.

③ See AMR Systems Register datasheet AMR-275 for details specifications.

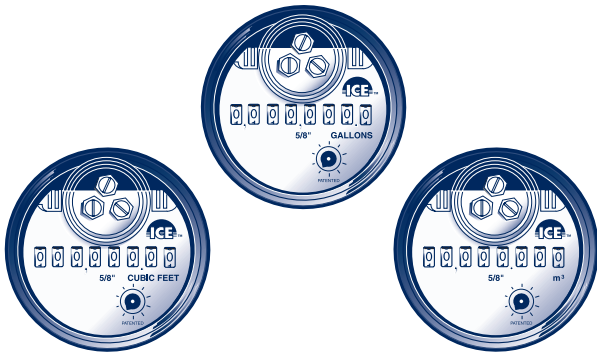

5/8" AMR System Dials Shown

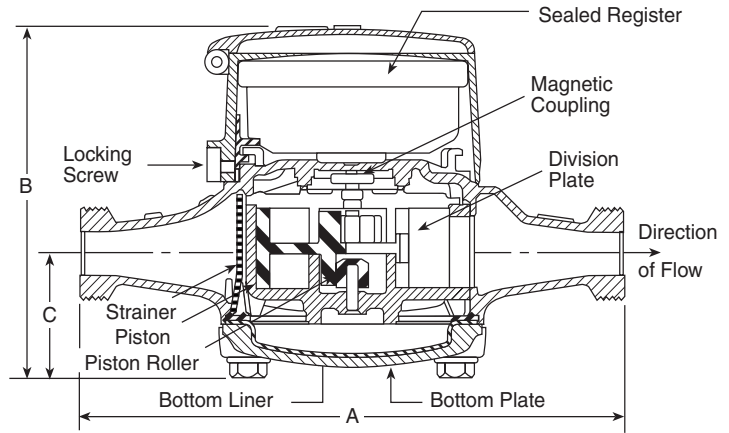

Dimensions and Net Weights

Meter Size	A	B	C	Width	Net Weight ^①
5/8" (DN 15mm)	7-1/2" (190mm)	5.0" (127mm)	1-3/4" (44mm)	3-7/8" (98mm)	4.3 lb. (1.97 kg)
5/8" x 3/4" (DN 15mm x 33mm)	7-1/2" (190mm)	5.0" (127mm)	1-3/4" (44mm)	3-7/8" (98mm)	4.4 lb. (2.00 kg)
3/4" (DN 20mm)	9" (229mm)	5-1/2" (140mm)	2-3/16" (56mm)	4-1/2" (114mm)	6.4 lb. (2.90 kg)
3/4" x 1" (DN 20mm x 42mm)	9" (229mm)	5-1/2" (140mm)	2-3/16" (56mm)	4-1/2" (114mm)	6.6 lb. (2.99 kg)
3/4" short (DN 20mm)	7-1/2" (190mm)	5-1/2" (140mm)	2-3/16" (56mm)	4-1/2" (114mm)	6.2 lb. (2.81 kg)
1" (DN 25mm)	10-3/4" (273mm)	6-9/16" (167mm)	2-7/16" (62mm)	6-1/2" (165mm)	11.9 lb. (5.4 kg)

① With Rocksyn[®] measuring chamber.

Remote Reading Systems

For use with all sizes of Sensus Water Meters

All Sensus AMR systems work with the same absolute encoder Electronic Communications Registers (ECR), enabling the utility to mix and match or easily move from one system to another without changing registers for each.

The TouchRead[®] Automated Meter Reading and Billing System—is a multipurpose encoder remote system suitable for indoor and/or outdoor use. The ECR Register uses a wired connection between the meter and an outside remote for inside set meters—or a pitlid mounted module, enabling underground meters to be read automatically without opening the meter box or vault. All wired connections and terminals of the TouchRead PitLid (TR/PL) modules and registers are fully sealed at the factory using a special process to ensure protection from water infiltration. The connection terminals of ECR/WP registers are also factory sealed.

Meters equipped for TouchRead System reading can be read with a visual reading device, stand alone AutoGun, and/or reading gun with an AutoRead HandHeld Device. For more information on TouchRead System equipment refer to bulletins AMR-TR, AMR-401, AMR-403, AMR-312 and EXSUMHH.

PhonRead[®] AMR—is a reliable telephone based call-in system that does not require batteries for operation. It also does not require equipment to be installed at telephone company facilities. PhonRead

Meter Interface Units (MIU) automatically call "in" to the utility office for transferring meter reading data from the meter site to a PC. PhonRead is a transparent AMR system that does not interfere with customers' telephone service. For more information refer to bulletins AMR-PR and AMR-302.

RadioRead[®] AMR—uses superior Direct Sequence Spread Spectrum modulation to provide reliable, safe and virtually interference free radio-based transmission of reading data from underground or inside-set meters that are equipped with Meter Transceiver Units (MXU). A choice of meter reading options is available. A radio frequency hand-held device (RF-HHD) can be used by a meter reader on foot. The RF-HHD can also be used to collect readings from TouchRead equipped meters, or for manual meter reading entries. A more powerful Vehicle Transceiver Unit (VXU) can be used in any car or truck to read meters while on the move. (A dedicated meter reading vehicle is not required.) For more information refer to bulletins AMR-RR, AMR-301 and AMR-303, and AMR-401.

MultiRead[®] Port Expanders—can provide the capability to connect multiple ECR equipped meters to a single PhonRead MIU or RadioRead MXU to save the utility time and money for installations such as apartment complexes and shopping centers. Refer to bulletin AMR-305, AMR-306 and AMR-308.

AUTHORIZED SENSUS DISTRIBUTOR



P.O. Box 487 • 450 N. Gallatin Avenue
Uniontown, PA 15401
1-800-METER-IT • 1-800-638-3748

Fax: Direct to Factory
Local: 724-439-7729 • Toll Free: 1-800-888-2403

www.sensus.com (select "North America Water")

Email: h2oinfo@sensus.com